

ADDRESSABLE SOUNDER STROBE

The NFA-T01ST Addressable Sounder Strobe is an alarm warning device used to alert individuals in the vicinity of a fire emergency, prompting to take necessary precautions. The NFA-T01ST Sounder Strobe combines multiple applications, including various types, parameters, and wiring layouts within a single device. Using Programming Tool, the NFA-T01ST can be configured for different alarm warning modes, such as sounder strobe, sounder only, or strobe only. Additionally, parameters can be adjusted to meet specific requirements, including selecting from 17 different alarm tones, choosing between single or dual address modes, and optimizing power consumption through simple programming. The NFA-T01ST is manufactured in accordance with EN 54-3 and LPCB approved.



FEATURES & BENEFITS

- LPCB approved
- EN 54-3 :2014 + A1:2019
- Built in processor and digital addressing
- Programmable types such as sounder strobe, sounder or strobe alone
- 17 tones programmable sound output
- Programmable evacuate or pre alarm signal
- One or two address mode
- 10 Highlights LED status cluster
- Loop or external power input
- Onsite adjustable parameter

TECHNICAL INFORMATION

Characteristic	Value
Listed	LPCB
Certified	EN 54-3 :2014 + A1:2019
Operating Voltage	Loop Power:24 VDC[18V to 27.5V DC] External PSU:24 VDC [20V to 27.5]
Current Consumption	Loop :Stand by: 0.6mA, Alarm:1.5mA External PSU: Stand by0.6mA, Alarm:1.5mA
Saving Current Consumption	Stand by 1.2mA, Alarm:9mA
Addressing	Value ranges from 1 to 254,default 1 address, if set to dual address:1st Alert& 2nd Evacuation
Sounder Level Pressure	102dBA at 1 meter/ tone 14
Tone	17 Tones (refers to Manual)
Strobe Light	10 Highlights LED
Material/Colour	ABS/Red glossy finishing

ADDRESSABLE SOUNDER STROBE

TECHNICAL INFORMATION

Characteristic	Value
Dimension/Weight	Diameter:110mm/39.6mm(with a base)
Weight	176g (With base)/110g (without base)
Ingress Protection Rating	IP21/Type A,indoors
Operating Temperature	-10°C to 50°C
Humidity	0 to 95% Relative Humidity, Non condensing

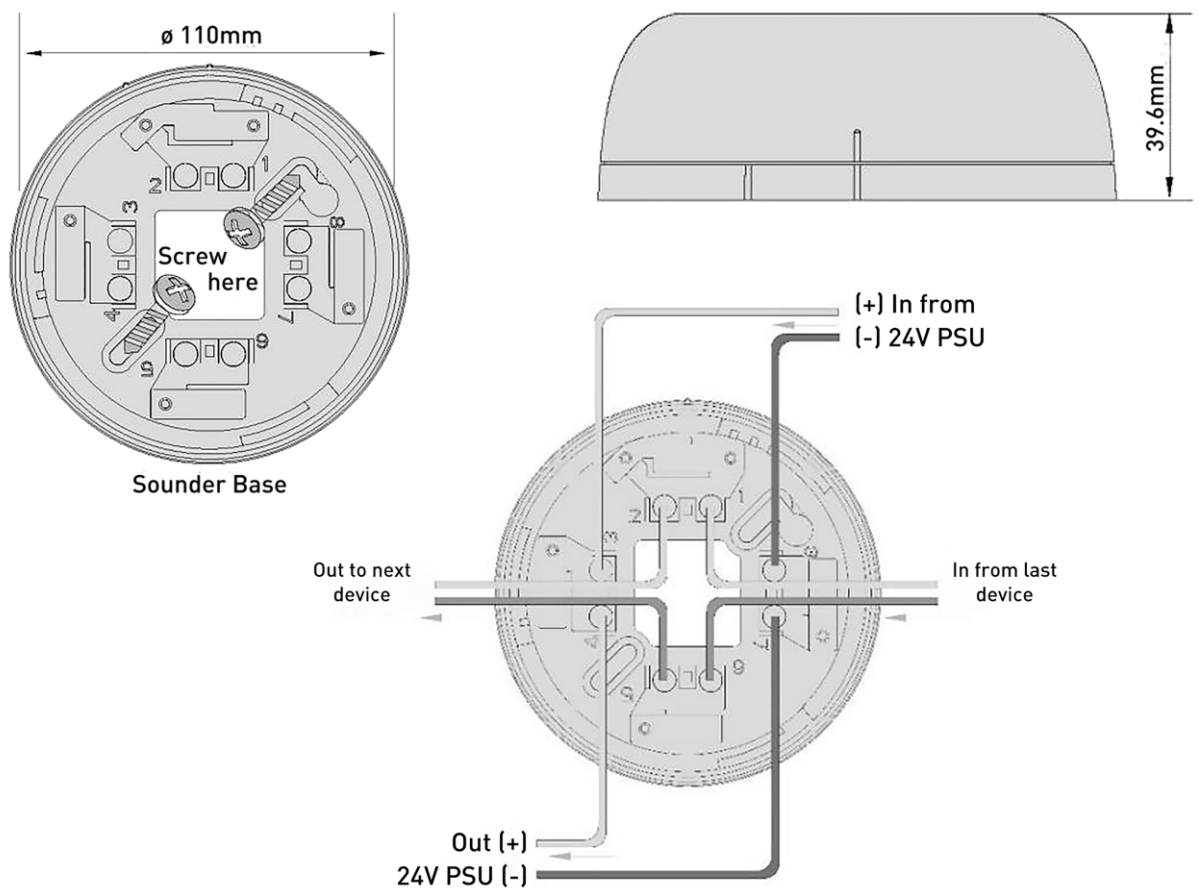

ORDERING INFORMATION

Part Number	Description
NFA-T01ST	Addressable Sounder combined Sounder and Strobe with ultra bright LED light source, Loop powered or external 24VDC powered.LPCB Approved,EN 54-3 :2014 + A1:2019 Complied.