

IP DUAL SENSOR THERMAL PTZ CAMERA



ENC-HHP7Z-37X-39

FEATURES

640x512 Uncooled VOx Micro Bolometer Detector

Sensitivity $\leq 40\text{mK}$

25/50/75/100 mm Motorized Focus Thermal Lens

Areas / Spot / Line Temperature Measurement Rule Support

17 Color Patterns Support

IP67



SPECIFICATION

MODEL	Model No.	ENC-HHP7Z-37X-39
	Type	IP DUAL SENSOR THERMAL PTZ CAMERA
THERMAL CAMERA	Detector Type	Uncooled VOx Focal Plane Arrays
	Effective Pixels	640x512 and Image can be scaled up to 1280x1024
	Pixel Size	17um
	Thermal Sensitivity (NETD)	$\leq 40\text{ mK}$
	Spectral Range	8~14um
	Image Settings	Brightness, Sharpness, Contrast, Mirror, 3D DNR, Mirror / Flip, FFC
	Color Palettes	White & Black Hot, Ironbow, Rainbow etc. up to 17 modes
	Iris	Auto Fixed IRIS
THERMAL LENS	Lens	Fixed
	Focus Control	Motorized Focus
	Focal Length	25/50/75/100 mm
	F No	1.0
	Angle of View	25 mm: 17.0° (H), 14.0° (V) 50mm: 8.0° (H), 7.0° (V) 75 mm: 6.0° (H), 5.0° (V) 100 mm: 4.3° (H), 3.5° (V)
	Detection	25 mm: Human(1.8mx0.5m) - 1040 m, Vehicle(4.0mx1.5m) - 3194 m 50 mm: Human(1.8mx0.5m) - 2081 m, Vehicle(4.0mx1.5m) - 6389 m 75 mm: Human(1.8mx0.5m) - 3121 m, Vehicle(4.0mx1.5m) - 9583 m 100 mm: Human(1.8mx0.5m) - 4161 m, Vehicle(4.0mx1.5m) - 12778 m
	Recognition	25 mm: Human(1.8mx0.5m) - 1040 m, Vehicle(4.0mx1.5m) - 3194 m 50 mm: Human(1.8mx0.5m) - 2081 m, Vehicle(4.0mx1.5m) - 6389 m 75 mm: Human(1.8mx0.5m) - 3121 m, Vehicle(4.0mx1.5m) - 9583 m 100 mm: Human(1.8mx0.5m) - 4161 m, Vehicle(4.0mx1.5m) - 12778 m
	Identification	25 mm: Human(1.8mx0.5m) - 130 m, Vehicle(4.0mx1.5m) - 399 m 50 mm: Human(1.8mx0.5m) - 260 m, Vehicle(4.0mx1.5m) - 799 m 75 mm: Human(1.8mx0.5m) - 390 m, Vehicle(4.0mx1.5m) - 1198 m 100 mm: Human(1.8mx0.5m) - 520 m, Vehicle(4.0mx1.5m) - 1597 m
	Fire Detection	25 mm: Fire(0.2mx0.2m) - 208 m, Fire(1.0mx1.0m) - 1042 m 50 mm: Fire(0.2mx0.2m) - 417 m, Fire(1.0mx1.0m) - 2083 m 75 mm: Fire(0.2mx0.2m) - 625 m, Fire(1.0mx1.0m) - 3125 m 100 mm: Fire(0.2mx0.2m) - 833 m, Fire(1.0mx1.0m) - 4167 m

★Product specification and availability are subject to change without notice.

IP DUAL SENSOR THERMAL PTZ CAMERA



ENC-HHP7Z-37X-39

MODEL	Model No.	ENC-HHP7Z-37X-39
	Type	IP DUAL SENSOR THERMAL PTZ CAMERA
VISIBLE CAMERA	Image Sensor	1/1.8" Sony CMOS
	Max Resolution	2592 x 1520
	Focal Length	6.8 ~ 251 mm
	Optical Zoom	37x
	Digital Zoom	16x
	Focus Control	Auto/Manual
	Max Aperture	F1.5 ~ F4.8
	Angle of View(H)	60.7° ~ 2.3°
	Angle of View(V)	36.8° ~ 1.3°
	Angle of View(D)	70.9° ~ 2.6°
	Shutter Speed	1s ~ 1/100,000s, Auto/Manual
	Min. illumination	Color: 0.001 lux @ F1.2, B/W:0.0001 lux
	AGC	Auto/Manual
	S/N Ratio	≥55 dB
	Defog	Smart Defog
WDR	120dB	
Wavelength	850 nm	
DORI	Lens	6.8 ~ 251 mm
	Detection	149.7 ~ 3850.0 m
	Observation	60.0 ~ 1552.4 m
	Recognition	29.4 ~ 770.0 m
	Identification	14.2 ~ 385.0 m
VIDEO	Video Compression	Enhanced (H.265, H.264), H.265, H.264, MJPEG
	Frame Rate	Main Stream: Thermal: (1280×1024, 1280×720, 640×512) @25/30fps; Visible: (2592×1520, 2304×1296, 1920×1080, 1280×720) @25/30fps Sub Stream: Thermal: (704×576, 352×288) @25/30fps; Visible: (704×576, 640×480, 352×288)@25/30fps
	Stream Settings	i-Frame, PAL/NTSC, Frame Rat
	Bit Rate Control	CBR, VBR
	Bit Rate	Thermal: 100Kbps ~ 6Mbps Visible: 100Kbps ~ 16Mbps
	HLC	Supported
	BLC	Supported
	OSD	Up to 8 regions
	OSD Type	Title, Week, Date, Time, Text with different colors and adaptable sizes (Small / Medium / Big), Image overlay
	ROI	Up to 8 regions
Privacy Masking	Up to 4 regions	
AUDIO	Audio Compression	G.711A, G.711U, RAW_PCM
	Audio Bitrate	64 kbps ~ 128kbps
	Audio I/O	2/2
SMART	Behaviour Detection	Thermal/Visible: Intrusion (Perimeter), Crossline (Tripwire), Double Crossline (Double Tripwire)
	Intelligent Identification	Thermal/Visible: Loitering, Region Entry / Exit Detection, Smoke Detection, Flame Detection, Flame Point Detection
	Statistical Analysis	Thermal/Visible: People Counting, Wrong Way Detection, Human and Vehicle Detection, Temperature Detection
	Alarm Management	Motion Detection, Tampering Alarm, Disk Full Alarm, Temperature Alarm, Input / Output Alarm, Network Alarm
	Alarm Notification	E-mail (Notification & Snapshot), HTTP (Alarm icon), FTP (Snapshot & Recording), SD Card (Recording)
TEMPERATURE	Detection Mode	Spot, Line, Area (Total 20 Rules - 1 Full Screen and 19 others)
	Alarm	Over/Difference Alarm
	Accuracy	±2°C / ±2%
	Response Time	≤ 30ms
	Measurement range	-40°C ~ 150°C (-4°F to 302°F)

★Product specification and availability are subject to change without notice.

IP DUAL SENSOR THERMAL PTZ CAMERA



ENC-HHP7Z-37X-39

MODEL	Model No.	ENC-HHP7Z-37X-39	
	Type	IP DUAL SENSOR THERMAL PTZ CAMERA	
INTERFACE	Protocols	TCP/IP, UDP, IPv4, IPv6, ICMP, HTTP, HTTPS, FTP, DHCP, DNS, DDNS, RTP/RTCP, RTSP, PPPoE, NTP, UPnP, SMTP, SNMP, IGMP V2/V3, 802.1x, QoS, Unicast, Multicast, SNMP, ARP, SSL / TLS 1.2	
	Security	AES Video Encryption, IP Filter, User Authentication (Multiple Privilege Level), HTTPS Authentication, Digest Authentication, User Access Log	
	Compatibility	ONVIF (Profile S, G, T), CGI/SDK	
	Network	1x RJ45 10M/100M Self Adaptive Ethernet Port	
	Serial Interface	1xRS485	
	BNC Output	Supported	
	Edge Storage	SD card slot, up to 512 GB	
	Alarm Interface	9/4	
	Heater & Blower	Supported (Optional)	
	Wiper	Supported	
	Max.User	32	
	Client Application	EyeGuard	
	PAN AND TILT	Pan Range	0° ~ 360° (Endless)
		Pan Speed	Pan Manual Speed: 0.01° ~ 60°/s, Pan Preset Speed: 60°/s
Tilt Range		-75° ~ 40°	
Tilt Speed		Tilt Manual Speed: 0.01° ~ 30° /s, Tilt Preset Speed: 30°/s	
Preset Accuracy		±0.2°	
Number of Presets		400	
Power Off Memory		Supported	
3D Position		Supported	
PTZ Mode		6 Track, 8 Scan, 12 Patrol (Up to 32 Presets per Patrol)	
Speed Setup		Auto/Manual (0-8)	
GENERAL	Power Supply	36V DC	
	Max. Power consumption	≤100W	
	Working Temperature	-40 °C ~ 70 °C	
	Working Humidity	≤95% RH	
	Casing	Metal	
	Ingress Protection	IP67	
	Vandal Resistant	IK10 (Housing)	
	Surge Protection	TVS6000V	
	Reset Button	Supported	
	Dimensions	25/50/75mm Lens: 293 × 420 × 520 mm 100 mm Lens: 333 × 490 × 550 mm	
Weight	25/50/75mm Lens: 26 Kg 100mm Len: 28 Kg		

Dimension Unit : mm

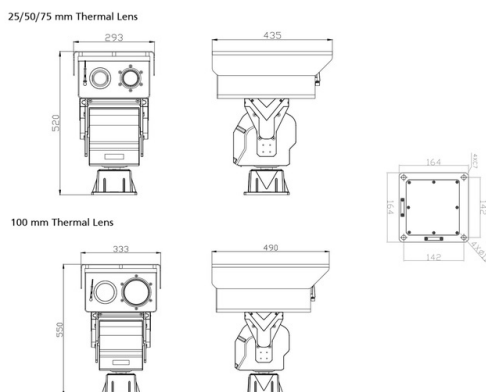

★Product specification and availability are subject to change without notice.

IP DUAL SENSOR THERMAL PTZ CAMERA



ENC-HHP7Z-37X-39

ORDERING INFORMATION

Part Number	Description	Standard Quantity
ENC-HHP7Z-37X-39	4MP IP Dual Sensor Temperature Detection Thermal PTZ Camera with Visible Lens of 37X Optical Zoom and Thermal Imaging Camera with 640*512 Thermal Resolution and SD Card Slot Support	1

PACKING INFORMATION

Part Number	Packing Mode	Gross weight(Kg)	Dimension(mm)
ENC-HHP7Z-37X-39	Carton Box	-	-