

THREE PANEL IR ILLUMINATOR



ENI-HSA030-700R

FEATURES

90 pcs LED

111 W IR Illuminator

700 m Distance Support

IP66



SPECIFICATION

MODEL	Model No.	ENI-HSA030-700R
	Type	THREE PANEL IR ILLUMINATOR
GENERAL	Beam Angle	10° ~ 30°
	Beam Distance	700 m
	Best Distance for LPR	350 ~ 700 m
	Day / Night	Auto
	Design Lifetime	≥50000 Hrs
	Color	Black
	LED	90 pcs LED
	Wavelength	850 nm
	Power Supply	12V DC / 24V AC / 85 ~ 265V AC
	Power Consumption	≤111 W
	Working Temperature	-40 °C ~ 50 °C
	Ingress Protection	IP66
	Surge Protection	Common mode: 6KV, Differential mode: 3KV
	Material	Aluminium
Panel	Tempered glass	
Dimensions	610×206×117 mm	
Net Weight	12 kg	
INSTALLATION	Power	The Power and LED panel wires must be oriented downward to prevent water intrusion.
	Earthing	Lighting safety precautions must be taken and power wires must be grounded.
	Settings	Gently modify the bolt of brightness, sensor and time.
	Installation	Professional electricians or quality technicians should install and adjust.
	Caution	Before opening the casing, disconnect the power supply.

★Product specification and availability are subject to change without notice.

THREE PANEL IR ILLUMINATOR



ENI-HSA030-700R

Dimension Unit : mm

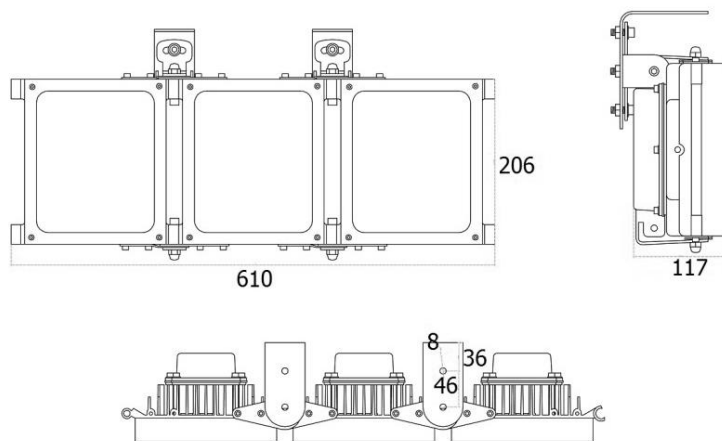

ORDERING INFORMATION

Part Number	Description	Standard Quantity
ENI-HSA030-700R	Three Panel IR illuminator with 90 pieces high power IR LED, 30° Beam Angle, 700m IR , IP66 and IK10 Support	1

PACKING INFORMATION

Part Number	Packing Mode	Gross weight(Kg)	Dimension(mm)
ENI-HSA030-700R	Carton Box	-	-