



**INTELLIGENT ADDRESSABLE  
MULTI DETECTOR  
INSTALLATION AND OPERATION MANUAL**

## Product Safety

To prevent severe injury and loss of life or property, read the instructions carefully before installing the Isolator to ensure proper and safe operation of the system.



### European Union directive

2012/19/EU (WEEE directive): Products marked with this symbol cannot be disposed of as unsorted municipal waste in the European Union. For proper recycling, return this product to your local supplier upon the purchase of equivalent new equipment, or dispose of it at designated collection points.

For more information please visit the website at [www.recyclethis.info](http://www.recyclethis.info)

## EN54 Part 29, Part 5, Part 7 Compliance

NFA-T01MD Intelligent Addressable Multi Detector complies with the requirements of EN 54-29:2015, EN 54-5: 2017 + A1: 2018, EN 54-7:2018



EN54 Standard Conformity Information



EN54-29:2015  
1330j/01

NORDEN COMMUNICATION UK LTD Unit 10 Baker Close, Oakwood Business Park Clacton-On- Sea, Essex POST CODE:CO15 4BD NFA-T01MD
EN 54-29:2015

## Table of Content

1	Introduction.....	4
1.1	Overview.....	4
1.2	Feature and Benefits.....	4
1.3	Technical Specification.....	4
2	Installation.....	5
2.1	Installation Preparation.....	5
2.2	Installation and Wiring.....	5
3	Detector Configuration.....	6
3.1	Preparation.....	6
3.2	Write: Addressing.....	6
3.3	Set: LED On/Off.....	7
3.4	Read Configuration.....	7
4	General Maintenance.....	8
4.1	Cleaning.....	8
5	Troubleshooting Guide.....	9
Appendix 1.....		9
	Limitation of Intelligent Addressable Multi Detector.....	9

# 1.Introduction

## 1.1.Overview

The NFA-T01MD Intelligent Addressable Multi Detector stands out as an excellent choice for various applications. It's remarkable linear response effectively detects a wide range of smoke patterns, and it also includes a heat-sensing sensor for temperature monitoring. Manufactured in accordance with the sensitivity requirements outlined in EN 54 part 29, European Standard, this unit combines functionality with aesthetics. Its unobtrusive design seamlessly complements modern building architecture. Additionally, the NFA-T01MD features an intelligent processor that offers an algorithm map, an inbuilt A/D converter, drift compensation, and self-diagnosis capabilities, along with a comprehensive history log.

The NFA-T01 Intelligent addressable multi detector leverages its on-board processor for secure and rapid communication, allowing the detector to autonomously make critical decisions. In the event of a fire, the integral microprocessor meticulously analyses the incoming signal, considering factors such as signal strength and rate of increase. It then cross-references these patterns with pre-programmed fire scenarios, including smoke and heat patterns (such as fixed temperature), ensuring a swift and safer response.

Once the analysis confirms the presence of a fire, the LED indicator reflects the sensor's status, and a parallel communication signal is dispatched to the control panel. Notably, the NFA-T01MD detector seamlessly integrates with the NFA-T04FP Intelligent Addressable Fire Alarm Control Panel. This compatibility ensures smooth addressable communication, eliminating any compatibility issues

## 1.2.Feature and Benefits

- EN 54-29:2015, EN 54-5: 2017 + A1: 2018, EN 54-7:2018 Compliance
- Using microprocessor technology with memory capacity up to 10 events
- Analogue sensing and digital addressing
- Provide real time algorithm to the control panel
- Smart linear drift compensation
- 360 degree visual indicator
- Onsite Adjustable Parameter
- Removable chamber against dust and small insect
- Ancillary remote indicator output
- Aesthetically pleasing design

## 1.3.Technical Specification

- |                               |   |
|-------------------------------|---|
| • Listed                      | LPCB Certification                                    |
| • Compliance                  | EN 54-29:2015, EN 54-5: 2017 + A1: 2018, EN 54-7:2018 |
| • Input Voltage               | 24VDC [16V to 28V]                                    |
| • Current Consumption Standby | 0.6mA, Alarm: 4mA                                     |
| • Protocol/Addressing         | Norden, Value ranges from 1 to 254                    |
| • Smoke Sensitivity           | As per stipulated standard                            |
| • Heat Category Type          | A2R   |
| • Indicator                   | Single LED / 360 degree Visual                        |
| • Material / Colour           | ABS / White Glossy finishing                          |
| • Dimension / Height          | Diameter 99.7 mm / 57 mm                              |
| • Weight                      | 145g (with Base), 90g (without Base)                  |
| • Operating Temperature       | -10°C to +50°C  |
| • Humidity                    | 0 to 95% Relative Humidity, Noncondensing             |

## 2. Installation

### 2.1. Installation Preparation

This sensor must be installed, commissioned and maintained by a qualified or factory trained service personnel. The installation must be installed in compliance with all local codes having a jurisdiction in your area or BS 5839 Part 1 and EN54.

The NFA-T01MD Intelligent addressable multi detector operates on the principle of infra-red light refracting off smoke particles entering the chambers. This makes detector more sensitive to smouldering fires such as modern fabric or furnishing. Optical detectors are more prone to false alarm from steam or dusty environments. For best sensing ability, avoid installing the smoke detector in these areas.

- In open air applications, the detectors require ceilings to direct the smoke from the plume by convection.
- On side walls, this will severely delay the response time of a detector and where ceiling heights exceed 10.5m.
- In Rooms where cooking will take place such kitchens, or similar areas where steam and condensation are present.
- Where exhaust fumes are present like car parks.
- Where smoke particles will not be produced by fire.
- Plant Rooms (unless full discussions regarding the room contents and status subject to a fire have been made between Client and Manufacturer), Boiler and Generator Rooms.

### 2.2. Installation and Wiring

1. Mount the NFA-T01NB Normal base on standard one [1] gang electrical back box. Do not over-tighten the screws otherwise the base will twist. Use M4 standard screws.
2. Connect the wire in terminal as shown in Figure two [2]. Verify the device number or other device parameters if desired using Programming tool then stick on the label before attaching detector. The sticker labels are available on the control panel.
3. Attach the detector to the base, point the detector in the base by the mark-line and secure the detector in that position by rotating it clockwise, until it reaches the next mark line.
4. Do not remove the red plastic dust cover until the final handover is done .
5. The connecting line of remote indicator should be less than 30 meters.

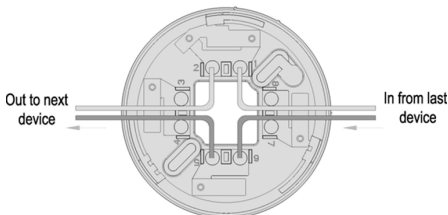

Figure 2

#### Terminal Description

- |   |                      |
|---|----------------------|
| 1 | Signal In (+)        |
| 2 | Signal Out (+)       |
| 3 | Remote Indicator (+) |
| 4 | Remote Indicator (+) |
| 5 | Signal In (-)        |
| 6 | Signal Out (-)       |
| 7 | Remote Indicator (-) |
| 8 | Remote Indicator (-) |

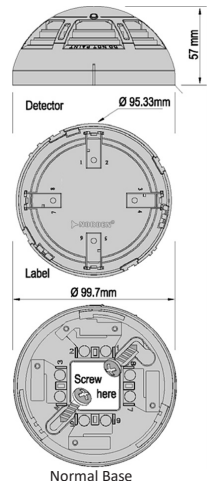

Figure 1

## 3. Detector Configuration

### 3.1. Preparation

The NFA-T01PT Programming tool is used to configure Intelligent addressable multi detector soft address and parameter. This Programming tool is not included, must be purchased separately. The programming tool is packed with twin 1.5V AA battery and cable, ready for usage once received. It is mandatory for the commissioning personnel to have programming tool enable to adjust the detector conferring to the site situation and environmental requirements. Program a unique address number for each device according to the project layout before placing from the Terminal Base.

**Warning:** Disconnect the loop connection whilst connecting to the programming tool.

### 3.2. Write: Addressing

1. Connect the programming cable to 1 and 6 terminals (Figure 3). Press “Power” to switch on the unit.
2. Switch-on the programming tool, then press button “Write” or number “2” to enter Write Address mode (Figure 4).
3. Input the desired device address value from 1 to 254, and then press “Write” to save the new address (Figure 5).

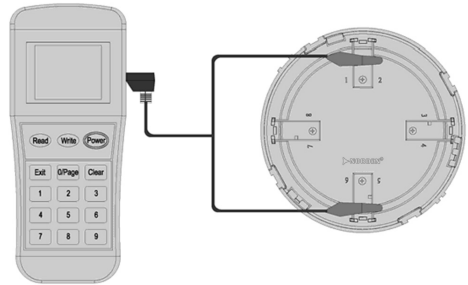

Figure 2

**Note :** If display “Success”, means the entered address is confirmed. If display “Fail”, means failure to program the address (Figure 6).

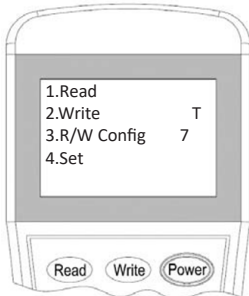

Figure 4



Figure 5



Figure 6

4. Press “Exit” key to go back Main Menu. Press “Power” key to switch-off the programming tool.

### 3.3.Set: LED On/Off

1. The LED can be turn-off if desire, the sensing ability of the detector will not disrupt even the LED is off.
2. Attach the programming cable to 1 and 6 Terminals of detector. Press “Power” to switch-on the unit.
3. Switch-on the programming tool, then press button “4” to enter to Setting mode (Figure 7). The programming tool will display the actual configuration after few seconds.
4. Input the “1” then press “Write” to change the setting (Figure 8) and LED will turn-off. To resume the default setting, press “Clear” and then press “Write”.

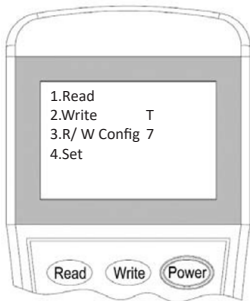

Figure 7

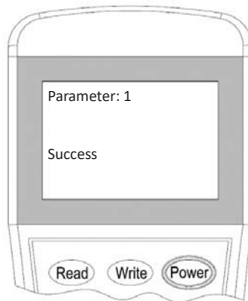

Figure 8

#### Parameter Description

- 0- LED On (Default)
- 1- LED Off

5. Press “Exit” key to go back Main Menu. Press “Power” to switch off the programming tool.

### 3.4.Read Configuration

1. Attach the programming cable to 1 and 6 terminals of detector. Press “Power” to switch on the unit.
2. Switch-on the programming tool, then press button “Read” or “1” to enter to Read mode (Figure 9). The programming tool will display the configuration after a few seconds. (Figure 10).

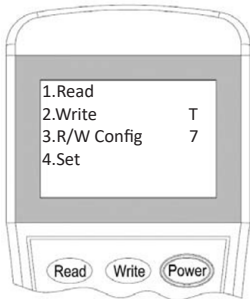

Figure 9



Figure 10

#### Read Description

- Address:** Unique number assigned
- Base: Value:** Detector status value
- ID:** Detector serial number

- 3 Press “Exit” key to go back to the Main Menu. Press “Power” key to switch off the programming tool.

## 4. General Maintenance

1. Inform the suitable personnel before conducting the maintenance.
2. Disable the detector on the control panel to prevent false alarm.
3. Do not attempt to adjust or modify the detector, it may affect the ability of the detector to respond to a fire condition and will void the manufacturer's warranty.
4. Use a damp cloth to clean the detector. Do not use cleaning chemicals that may leave residue on the electronic parts and smoke chamber.
5. Notify again proper personnel after conducting the maintenance and make sure to enable the detector and confirm if up and running.
6. Perform the maintenance on semi-annually or quarterly depending on the site conditions.

### 4.1. Cleaning

1. Remove the detector cover by snipping away the four sides tabs using a flat screwdriver and then pulling the cover from the base. (Figure 11)
2. Remove the protective screen by pulling it straight out. (Figure 12).
3. Carefully vacuum the chamber and screen. If there is stain, wash with running water and ensure it is completely dry.
4. Position the chamber and screen by aligning three tiny holes over the sensing component. (Figure 12).
5. Align the LED tube and tabs and gently pushing the cover until it locks into place. (Figure 12).
6. Re-install and test the detector.

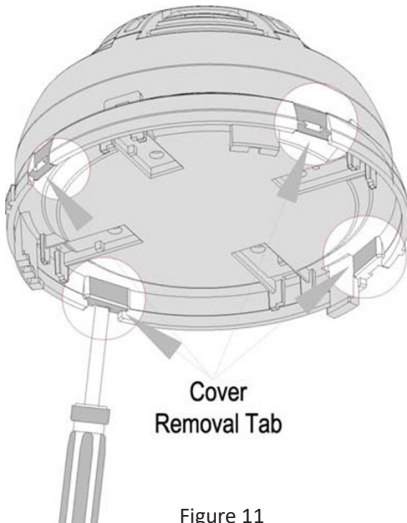

Figure 11

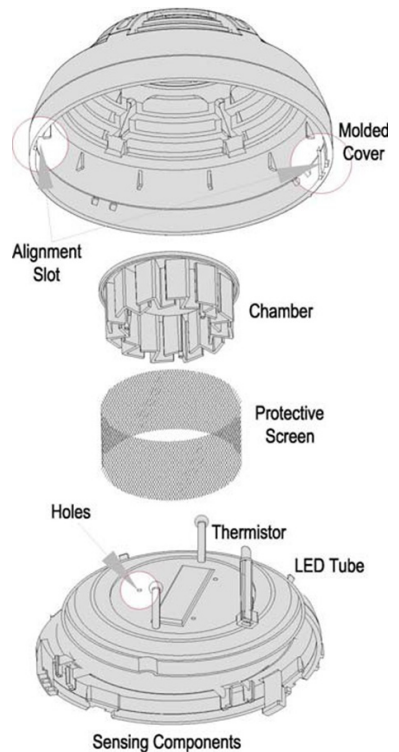

Figure 12 Exploded View



## 5.Troubleshooting Guide

What you notice	What it means	What to do
Address not enrolling	The wiring is loose The address is duplicate	Conduct maintenance Re-Commission the detector
Unable to commission	The damage is in the electronic circuit	Replace the detector
Keep Indicating Fire signal	The detector chamber is dirty	Clean the detector

## Appendix 1

### Limitation of Intelligent Addressable Multi Detector

The Intelligent addressable multi detector is designed for triggering and initiating emergency fire equipment's, however it only functions when matching with other equipment's. Installation of this Intelligent addressable multi detector must conform to electrical codes and standards in your country. All kinds of Intelligent addressable multi detector have restrictions, since fire develops in varies ways and are often unpredictable in their progression, it is unforeseeable which type of detector will provide the earliest warning. No types of Intelligent addressable multi detector can sense every form of fire all the time. Generally speaking, detectors may not warn you about fire caused by insufficient safety measures, violent explosions, leaking gas, improper storage of flammable materials like diluents and other safety hazards, arson or children playing with fire. The alarm of Intelligent addressable multi detector used in high velocity environment will be delayed due to dilution of smoke by frequent and fast airflow. What's more, the Intelligent addressable multi detector has to be frequently maintained for it is exposed to more dust contamination.

The Intelligent addressable multi detector cannot last forever. To keep the detector working in good condition, please maintain the equipment continuously according to recommendations from manufacturers and relative nation codes and laws. Take specific maintenance measures on the basis of different environments.

The Intelligent addressable multi detector contains electronic parts. Even though it is made to last for a long period of time, any of these parts could fail at any time. Therefore, test your Intelligent addressable multi detector at least every half-year according to national codes or laws. Any Intelligent addressable multi detector, fire alarm devices or any other components of the system must be repaired and/or replaced immediately as they fail.



**Norden Communication UK Ltd.**

Unit 10 Baker Close, Oakwood Business Park

Clacton-On- Sea, Essex

POST CODE:CO15 4BD

Tel : +44 (0) 2045405070 | E-mail : [salesuk@norden.co.uk](mailto:salesuk@norden.co.uk)

[www.nordencommunication.com](http://www.nordencommunication.com)