

8MP EXPLOSION PROOF PTZ CAMERA



ENC-HPTAZ-200R-23

FEATURES

304 / 316L Stainless Steel Construction

40X Optical Zoom, 16X Digital Zoom

ONVIF Profile (S, G, T)

Triple Stream

Wiper Support

ATEX/ IECEx/ CCoE (PESO) Certified

Applicable for GAS Zone 1, Zone 2, Class IIA, IIB, IIC

Applicable for Temperature Classes T1-T6

Applicable for Dust Zone 21, 22



SPECIFICATION

MODEL	Model No.	ENC-HPTAZ-200R-23
	Type	8MP EXPLOSION PROOF PTZ CAMERA
CAMERA	Image Sensor	1/1.8" CMOS Progressive 8.0 MegaPixel
	Day / Night	IR Cut Filter with Auto Switch
	Lens Type	Motorized Lens
	Focal Length	6~240 mm (optional 5~200 mm)
	Focus	Auto / Semi Auto / Manual
	Iris Type	DC Auto Iris
	Angle of View (H)	61.8° ~ 1.7° (Optional 71.4° ~ 2.1°)
	Angle of View (V)	34.9° ~ 0.9° (Optional 40.3° ~ 1.1°)
	Angle of View (D)	70.9° ~ 1.9° (Optional 81.9° ~ 2.3°)
	Aperture Range	F1.6 ~ F4.9
	Optical Zoom	40x
	Digital Zoom	16x
	Shutter	1s to 1/100,000s, Auto / Manual
	Min. Illumination	Color: 0.001 lux @ F1.6, B/W: 0 lux with IR on
AGC	Auto / Manual	
Digital Noise Reduction	2D & 3D DNR, Auto / Manual	
S/N Ratio	≥50 dB	
Defog	Smart Defog	
WDR	120 dB	
Smart IR	Up to 200m	

★Product specification and availability are subject to change without notice.

8MP EXPLOSION PROOF PTZ CAMERA



ENC-HPTAZ-200R-23

MODEL	Model No.	ENC-HPTAZ-200R-23
	Type	8MP EXPLOSION PROOF PTZ CAMERA
DORI	Lens	6~240 mm (optional 5~200 mm)
	Detection	136.0 ~ 5000.0 m (Optional 77.6 ~ 3413.8 m)
	Observation	54.4 ~ 2000.0 m (Optional 31.0 ~ 1365.8 m)
	Recognition	27.2 ~ 1000.0 m (Optional 15.5 ~ 682.8 m)
	Identification	13.6 ~ 500.0 m (Optional 7.8 ~ 341.4 m)
VIDEO	Max. Resolution	3840x2160
	Video Compression	Enhanced (H.265, H.264), H.265, H.264, MJPEG
	Frame Rate	Main Stream: (3840x2160, 2592x1520, 2304x1296, 1920x1080, 1280x720) @ 25/30 fps Sub Stream: (704x576, 640x480, 352x288) @ 25/30fps Third Stream: (640x480, 352x288, 320x240) @ 25/30fps
	Stream Settings	i-Frame, PAL/NTSC, Frame Rate, EIS
	Video Bit Rate	100 kbps ~ 16 Mbps
	Bitrate Type	CBR, VBR
	Image Settings	Brightness, Contrast, Saturation, Sharpness, Day/Night (Color, Mono, Auto), Flip/Mirror/Rotation, Multiple Scene & Profile
	White Balance	Auto, Day / Night, Tungsten, Manual
	HLC	Supported
	BLC	Supported
	OSD	Supported
	ROI	Up to 8 regions
	Privacy Mask	Up to 40 regions (each scene up to 8)
AUDIO	Audio Compression	G.711U, G.711A, RAW_PCM
	Audio I/O	1/1
	Audio Bit Rate	64 Kbps, 128 Kbps
SMART	Behavior Detection	Intrusion (Perimeter), Crossline (Tripwire), Double crossline (Double Tripwire)
	Intelligent Identification	Abandoned object (Object Left), Missing Object (Object Lost), Loitering, Multi Loitering
	Statistical Analysis	Face Detection , People Counting, Human & Vehicle Detection, Abnormal Video & Audio Detection, Wrong Way Detection, Illegal Parking
	Alarm Management	Motion Detection, Tampering (Masking), Input & Output Event, Network Alarm, Disk Alarm, Day Night Switch Alarm, Abnormal Audio Alarm, Pre/Post Alarm Recording, Alarm Recording/Snapshot
	Alarm Notifications	E-mail (Notification & Snapshot), HTTP (Alarm icon), FTP (Snapshot & Recording), SD Card (Recording)
INTERFACE	Protocols	TCP/IP, UDP, IPv4, IPv6, ICMP, HTTP, HTTPS, FTP, DHCP, DNS, DDNS, RTP, RTSP, RTCP, PPPoE, NTP, UPnP, SMTP , IGMP, 802.1X, Unicast, Multicast, QoS, ARP, SNMP, Telnet, SSL/TLS1.2
	Security	TLS 128 Encryption, IP Filter, User Authentication (Multiple Privilege Level), 802.1X Authentication (EAP-MD5), HTTPS Authentication, RTSP Authentication, Digest Authentication, User Access Log
	Compatibility	ONVIF (S, G, T) , SDK, CGI
	Network	1 x RJ45 10M/100M Self Adaptive Ethernet Port
	Alarm Interface	1 Input / 1 Output
	Serial Interface	1xRS485
	CVBS output	Supported
	Edge Storage	SD card slot, up to 512 GB
	ANR	Supported
	Buil-in Heater	Supported
	Max User	32
Client Application	EyeGuard	
Wiper	Supported	

★Product specification and availability are subject to change without notice.

8MP EXPLOSION PROOF PTZ CAMERA



ENC-HPTAZ-200R-23

MODEL	Model No.	ENC-HPTAZ-200R-23
	Type	8MP EXPLOSION PROOF PTZ CAMERA
PAN AND TILT	Pan Range	360° (Endless)
	Pan Speed	Pan Manual Speed: 0.1°/s ~ 45°/s, Pan Preset Speed: 45°/s
	Tilt Range	-90 ~ +90°
	Tilt Speed	Tilt Manual Speed: 0.1°/s ~ 45°/s, Tilt Preset Speed: 45°/s
	Preset Accuracy	±0.1°
	3D Position	Supported
	Cruise Scan	Supported
	Tour	12 (32 Preset per Tour)
	Pattern	6
	Preset	255
	Resume function	Supported
GENERAL	Power Supply	AC 110V ~ 240V / 24V DC / 24V AC / PoE++ (802.3bt-Type 4)
	Max. Power Consumption	75W (with thermostat)
	Working Temperature	-40 °C ~ 70 °C
	Working Humidity	0-95% RH (non-condensing)
	Atmospheric pressure	80 kPa ~ 120 kPa
	Window glass	Strong tempered glass
	Sun shade	Supported
	Ingress Protection	IP66, IP68
	Surge Protection	TVS6000V
	Reset Button	Supported
	Dimensions	530x300x425 mm
Net Weight	45 kg	

Dimension Unit : mm

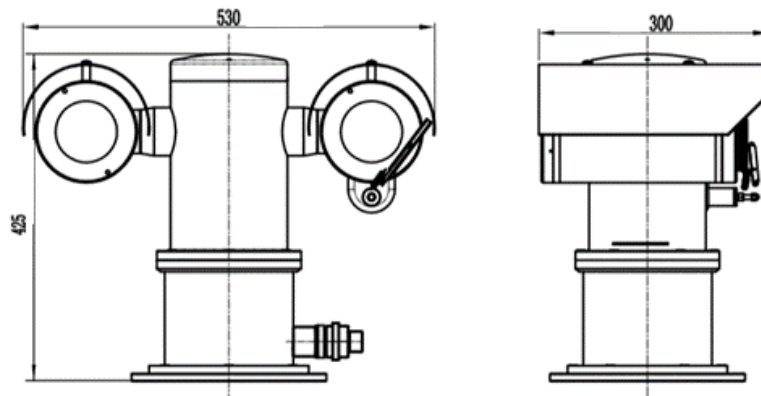

8MP EXPLOSION PROOF PTZ CAMERA



ENC-HPTAZ-200R-23

ORDERING INFORMATION

Part Number	Description	Standard Quantity
ENC-HPTAZ-200R-23	8MP SS316L (optional SS304) Explosion-Proof IR IP PTZ Camera with 40X Optical Zoom, Wiper, SD Card Slot and 200m IR Support	1
ENB-BZPW68	Wall Mount Bracket for Norden Explosion / Corrosion Proof PTZ Camera	1
ENB-BZPH68	Corner Mount Bracket for Norden Explosion / Corrosion Proof PTZ Camera	1
ENB-BZPV68	Pole Mount Bracket for Norden Explosion / Corrosion Proof PTZ Camera	1
ENA-EXH010	1 Meter Explosion / Corrosion Proof Hose for Norden Explosion / Corrosion Proof Camera	1
ENA-EXH015	1.5 Meter Explosion / Corrosion Proof Hose for Norden Explosion / Corrosion Proof Camera	1
ENA-EXH020	2 Meter Explosion / Corrosion Proof Hose for Norden Explosion / Corrosion Proof Camera	1
ENA-EXH030	3 Meter Explosion / Corrosion Proof Hose for Norden Explosion / Corrosion Proof Camera	1

PACKING INFORMATION

Part Number	Packing Mode	Gross weight(Kg)	Dimension(mm)
ENC-HPTAZ-200R-23	Carton Box	-	-