

JUNCTION BOX FOR DOME CAMERA



ENH-CDJ6600

FEATURES

Aluminum Alloy Housing
Easy and Flexible Installation
IP66



SPECIFICATION

MODEL	Model No.	ENH-CDJ6600
	Type	JUNCTION BOX FOR DOME CAMERA
GENERAL	Material	Aluminum Alloy
	Application	Junction Box For Wall Installation of Fixed Dome Cameras
	Color	White
	Dimensions	Φ 109 x 39 mm
	Weight	0.2kg

Dimension Unit : mm

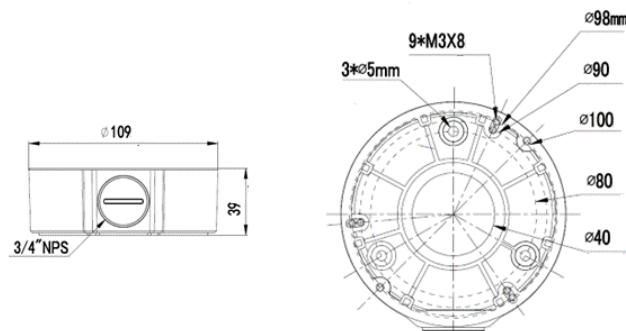

ORDERING INFORMATION

Part Number	Description	Standard Quantity
ENH-CDJ6600	Junction Box for Norden Fixed Dome Camera	1

PACKING INFORMATION

Part Number	Packing Mode	Gross weight(Kg)	Dimension(mm)
ENH-CDJ6600	Carton Box	0.2	117 x117x36