

NAC-9002AE

Aluminium Exit Button



DESCRIPTION

The NAC-9002AE is a Aluminium exit button which has a standard structure made of Stainless Steel panel and a steel button. It is suitable for hollow doors.

APPLICATION

Office areas, schools, communities, office buildings, hotels, shopping malls, shops, public service places, etc.

FEATURES

- NO/COM
- Standard structure of 8mm Aluminium Alloy

| TECHNICAL PARAMETERS | |
|-----------------------|------------------------------|
| Model | NAC-9002AE |
| Size | 86L x 50W x 25H mm |
| Weight | 0.12Kg |
| Power Supply | DC 12V |
| Output Contact | NO/COM |
| Material | 8mm Aluminium Alloy |
| Mechanical Life | 500,000 tested |
| Accessories | Optional Back box |
| Operating Temperature | -20°C ~ +55°C (-4°F ~ 131°F) |
| Operating Humidity | 0-95% (RH) |

NAC-9002AE

Aluminium Exit Button

DIMENSION

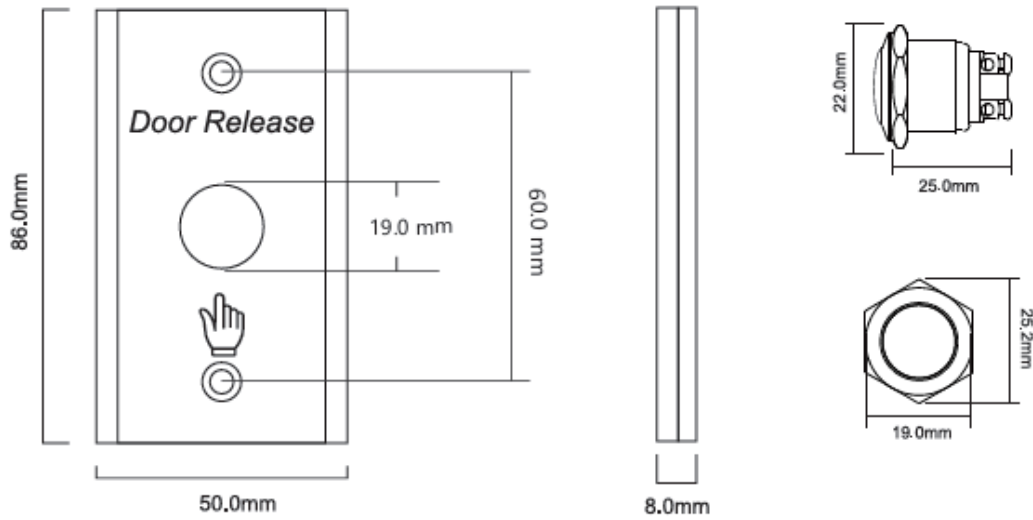

ORDERING INFORMATION

| Part Number | Description |
|-------------|------------------------------|
| NAC-9002AE | Aluminium Exit Button |
| NAC-9002BB | Metal Backbox For NAC-9002AE |