

# 4MP CORROSION PROOF PTZ DOME CAMERA



**ENC-HPT7Z-40X-27**

## FEATURES

304 / 316L Stainless steel construction
5 ~ 200 mm Lens
40X Optical Zoom, 16X Digital Zoom
ONVIF Profile (S, G, T)
Triple Stream
Audio and Alarm Support
IP68

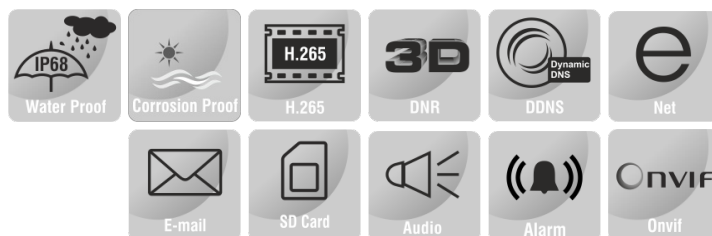

## SPECIFICATION

MODEL	Model No.	ENC-HPT7Z-40X-27
	Type	4MP CORROSION PROOF PTZ DOME CAMERA
CAMERA	Image Sensor	1/2.8" CMOS Progressive 4.0 MegaPixel
	Day / Night	IR Cut Filter with Auto Switch
	Lens Type	Motorized Lens
	Focal Length	5 ~ 200 mm
	Focus	Auto / Semi Auto / Manual
	Iris Type	DC Auto Iris
	Angle of View (H)	59.1° ~ 1.8°
	Angle of View (V)	38.4° ~ 1.1°
	Aperture Range	F1.2 ~ F3.5
	Optical Zoom	40X
	Digital Zoom	16X
	Shutter	1s to 1/100000s
	Min. Illumination	Color: 0.01 lux @ F1.2, B/W: 0.001 lux @ F1.2, 0 lux (External IR LED ON)
	AGC	Auto / Manual
	Digital Noise Reduction	3D DNR
	S/N Ratio	55 dB
	Defog	Smart Defog
WDR	120 dB	
Smart IR	Up to 180m	

# 4MP CORROSION PROOF PTZ DOME CAMERA



## ENC-HPT7Z-40X-27

MODEL	Model No.	ENC-HPT7Z-40X-27
	Type	4MP CORROSION PROOF PTZ DOME CAMERA
VIDEO	Max. Resolution	2592x1520
	Video Compression	H.265+, H.265, H.264, MJPEG
	Frame Rate	Main Stream: : 2592x1520/2560x1440/2304x1296/1920x1080/1280x720 @ 25/30fps Sub Stream:D1/VGA/640x360/CIF/QVGA @ 25/30fps Third Stream: VGA/CIF/QVGA @ 25/30fps SVC Stream: Support
	Stream Settings	i-Frame, PAL/NTSC, Frame Rate, EIS, SVC
	Video Bit Rate	10 kbps ~ 12 Mbps
	Bitrate Type	CBR, VBR
	Image Settings	Brightness, Contrast, Saturation, Sharpness, Day/Night
	White Balance	Auto, Day / Night, Tungsten, Manual
	HLC	Supported
	BLC	Supported
	OSD	Supported
	ROI	Up to 8 regions
	Privacy Mask	Up to 4 regions
	AUDIO	Audio Compression
Audio I/O		1/1
Audio Bit Rate		8 ~ 16 Kbps
SMART	Behavior Detection	Intrusion (Perimeter), Crossline (Tripwire), Double crossline ( Double Tripwire)
	Intelligent Identification	Abandoned object (Object Left), Missing Object (Object Lost),Loitering
	Statistical Analysis	Abnormal Speed, Wrong Way Detection, Illegal Parking, Signal Bad
	Alarm Management	Motion Detection, Tampering (Masking), IP Address Conflict, Pre/Post Alarm Recording, Alarm Recording/Snapshot
	Auto Tracking	Supported
INTERFACE	Protocols	TCP/IP, UDP, IPv4, IPv6, HTTP, HTTPS, FTP, DHCP, DNS, DDNS, RTP/RTCP, RTSP, PPPoE, NTP, UPnP, SMTP (SSL/TLS), IGMP, 802.1X, QoS, Unicast, SNMP, ARP
	Security	IP Address Filtering, User Authentication (Multiple Privilege Level), 802.1X Authentication, HTTPS Authentication, RTSP Authentication, Digest Authentication, User Access Log
	Compatibility	ONVIF (S, G, T) , SDK, CGI
	Network	1 x RJ45 10M/100M Self Adaptive Ethernet Port
	Alarm Interface	1 Interface / 1 Output
	Serial Interface	1xRS485
	CVBS Output	Supported
	Edge Storage	SD card slot, up to 256 GB
	ANR	Supported
Built-in Heater	Supported	
PAN AND TILT	Pan Range	360°
	Pan Speed	Pan Manual Speed: 0.1°/s ~ 300°/s, Pan Preset Speed: 300°/s
	Tilt Range	-90 ~ +0°
	Tilt Speed	Tilt Manual Speed: 0.1°/s ~ 250°/s, Tilt Preset Speed: 250°/s
	Preset Accuracy	±0.1°
	3D Position	Supported
	Cruise Scan	Supported
	Keep watch	Supported
	Preset	128
	Resume function	Supported
	Auto Cruise	Supported
	Auto Scan	Supported

# 4MP CORROSION PROOF PTZ DOME CAMERA



## ENC-HPT7Z-40X-27

MODEL		ENC-HPT7Z-40X-27
Type		4MP CORROSION PROOF PTZ DOME CAMERA
GENERAL	Power Supply	AC220 V
	Power Consumption	Max. 35W (with thermostat)
	Working Temperature	-25 °C ~ +60 °C
	Working Humidity	0-95% RH (non-condensing)
	Atmospheric pressure	80 kPa ~ 106 kPa
	Window glass	Strong tempered glass
	Sun shade	Supported
	Ingress Protection	IP68
	Corrosion Resistant	Sprayed with Oxygen, Hydrogen Sulphide, Carbon Dioxide and Nitrogen
	Surge Protection	TVS6000V
	Reset Button	Supported
	Dimensions	250x250x352 mm
	Net Weight	11.5 kg

Dimension Unit : mm

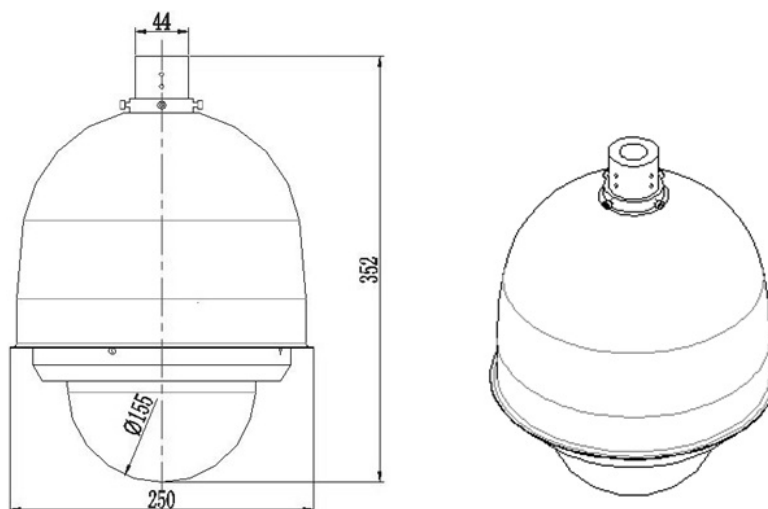

### ORDERING INFORMATION

Part Number	Description	Standard Quantity
ENC-HPT7Z-40X-27	4MP SS316L Corrosion Proof IP H.265 PTZ Camera with 40X Optical Zoom, SD Card Slot Support, Sunshade and Wall Mount Bracket	1
ENB-BZPW68	Wall Mount Bracket for Eyenor Explosion / Corrosion Proof PTZ Camera	1
ENB-BZPH68	Corner Mount Bracket for Eyenor Explosion / Corrosion Proof PTZ Camera	1
ENB-BZPV68	Pole Mount Bracket for Eyenor Explosion / Corrosion Proof PTZ Camera	1
ENA-EXH010	1 Meter Explosion / Corrosion Proof Hose for Eyenor Explosion / Corrosion Proof Camera	1
ENA-EXH015	1.5 Meter Explosion / Corrosion Proof Hose for Eyenor Explosion / Corrosion Proof Camera	1
ENA-EXH020	2 Meter Explosion / Corrosion Proof Hose for Eyenor Explosion / Corrosion Proof Camera	1

# 4MP CORROSION PROOF PTZ DOME CAMERA



ENC-HPT7Z-40X-27

## PACKING INFORMATION

Part Number	Packing Mode	Gross weight(Kg)	Dimension(mm)
ENC-HPT7Z-40X-27	Carton Box	-	-