

POLE MOUNT BRACKET FOR PTZ CAMERA



ENB-BZPV68

FEATURES

304 / 316L Stainless Steel Construction

Max. Load Support up to 100Kg

Pole Mount Bracket for Explosion / Corrosion Proof Camera

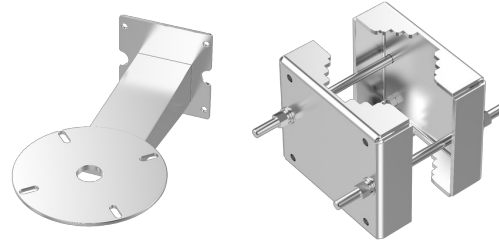

SPECIFICATION

MODEL	Model No.	ENB-BZPV68
	Type	POLE MOUNT BRACKET FOR PTZ CAMERA
GENERAL	Construction	304 / 316L Stainless Steel
	Max. Load Support	100 Kg
	Dimensions	490 × 220 × 180 mm, 280 × 182 × 202 mm
	Weight	13.3 Kg

Dimension Unit : mm

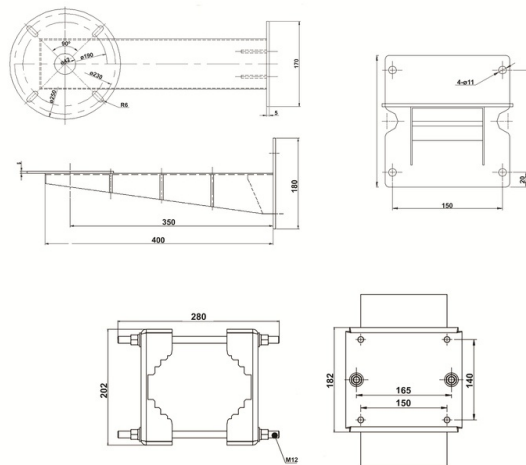

ORDERING INFORMATION

Part Number	Description	Standard Quantity
ENB-BZPV68	Pole Mount Bracket for Norden Explosion / Corrosion Proof PTZ Camera	1

PACKING INFORMATION

Part Number	Packing Mode	Gross weight(Kg)	Dimension(mm)
ENB-BZPV68	Carton Box	-	-

★Product specification and availability are subject to change without notice.

►NORDEN® | POLE MOUNT BRACKET FOR PTZ CAMERA - GB - Version: 2.1

www.nordencommunication.com