

# WALL MOUNT BRACKET FOR PTZ CAMERA



## ENB-BZPW68

### FEATURES

Alloy
Max. Load Support up to 100Kg
Wall Mount Bracket for Explosion/Corrosion Proof Camera



### SPECIFICATION

MODEL	Model No.	ENB-BZPW68
	Type	WALL MOUNT BRACKET FOR PTZ CAMERA
GENERAL	Construction	Alloy
	Max. Load Support	100 Kg
	Dimensions	490 x 220 x 180 mm
	Weight	6.5 Kg

Dimension Unit : mm

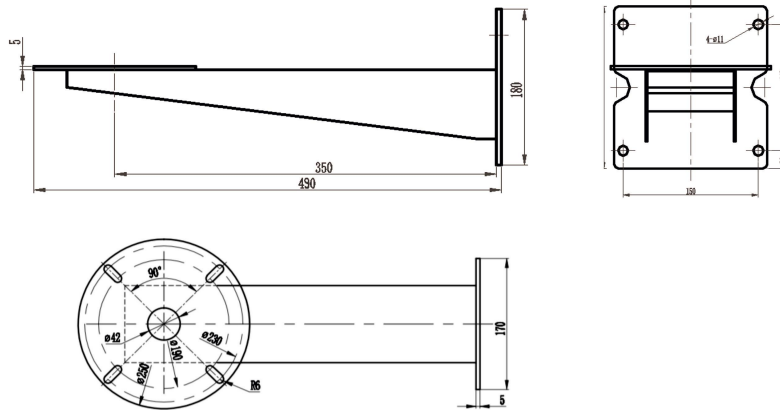

### ORDERING INFORMATION

Part Number	Description	Standard Quantity
ENB-BZPW68	Wall Mount Bracket for Eyenor Explosion / Corrosion Proof PTZ Camera	1

### PACKING INFORMATION

Part Number	Packing Mode	Gross weight(Kg)	Dimension(mm)
ENB-BZPW68	Carton Box	-	-

★Product specification and availability are subject to change without notice.