

# CORNER MOUNT BRACKET FOR DOME CAMERA



## ENB-BZDH68

### FEATURES

304 / 316L Stainless Steel Construction

Max. Load Support up to 100Kg

Corner Mount Bracket for Explosion / Corrosion Proof Camera

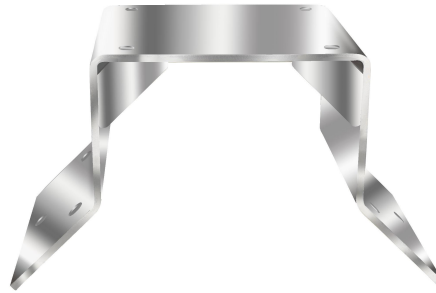

### SPECIFICATION

MODEL	Model No.	ENB-BZDH68
	Type	CORNER MOUNT BRACKET FOR DOME CAMERA
GENERAL	Construction	304 / 316L Stainless Steel
	Dimensions	326 x 184 x 180 mm
	Max. Load Support	100 Kg
	Weight	5.4 Kg

Dimension Unit : mm

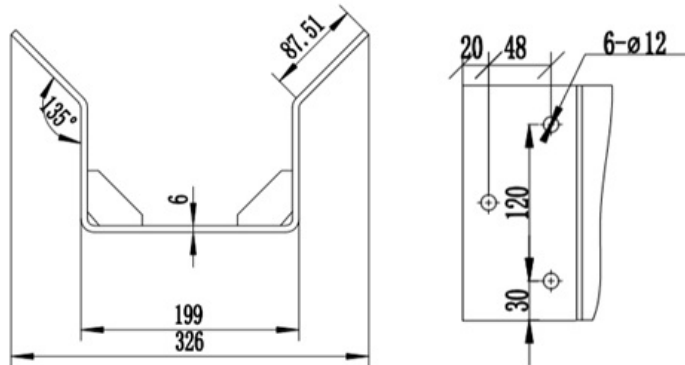

### ORDERING INFORMATION

Part Number	Description	Standard Quantity
ENB-BZDH68	Corner Mount Bracket for Norden Explosion / Corrosion Proof Dome Camera	1

### PACKING INFORMATION

Part Number	Packing Mode	Gross weight(Kg)	Dimension(mm)
ENB-BZDH68	Carton Box	6.0	420x200x230

★Product specification and availability are subject to change without notice.